

MULTIWIRE CUTTER NDF-6515/20-1400



1 – DESCRIPTION:

The new Diamond wire cutting machine NDF 6515/20-1400, is a multi-wire machine designed to produce boards and plates of varying thickness from the large blocks of granite and natural stone. This new unit represents the most modern technology in what refers to the primary sawing of the stone blocks, becoming the alternative to the traditionally used sawing methods, since it improves the production capacity quantitatively, efficiently taking advantage of the energy resources needed to the production of materials and significantly reducing the production costs of the cutting phase.

The multiple diamond wire cutter is a machine that stands out for its efficiency and high productivity, designed to obtain high yields, which is characterized by its great robustness, thanks to its particular design that forms a compact, balanced and balanced set where all movements are concentrated, and its proven reliability and that of the elements that compose it, being all designed to withstand the toughest working conditions.

The main structure of the machine is basically composed of two sturdy columns formed by two steel-welded steel structures, connected between them by an upper crossbar. On both columns the structure of the main frame that joins the two trolley-carriages is mounted, which move vertically supported on both columns on linear guides with linear roller recirculation skates and actuated by a pair of spindles rolled with recirculating nuts balls, synchronized and operated by two motor-reducers with independent servo motors for the ascent / descent of the threads with a smooth and precise movement, located in the upper part of both columns, the entire guide assembly is perfectly protected by PVC bellows . The servomotors are synchronized by software in the vertical movements that ensure smooth cutting, low consumption, and maximum precision and avoid the slacks and problems of the central motorization with transmission and forwarding.

The Ø1800 drive drum is formed by a single multi-channel pulley with grooves and connected to the main motor by a pulley and timing belt transmission. The threads are manually positioned according to the desired thickness supported by one side of the machine on the drive drum, and in turn are tensioned from the opposite

end by autonomous pulleys. The diamond wires are also guided by two multichannel drums that help to significantly reduce the arrow produced by them. From the opposite end to the driving drum, the diamond wires are supported by the set of idle pulleys, designed with a particular pivoting extraction system, which allows reducing maintenance times significantly.

Once the wires are located, these are adjusted with the active tensioning device that acts individually on each of the tensioning pulleys, independently ensuring that each of the threads has the same tension regardless of the minimum differences in length between each of the threads that are installed in the machine. The tensioning system manages to increase the useful life of the wires and therefore the profitability of the machine.

The whole machine is characterized by the robustness and reliability of the elements that compose, being all designed to withstand the toughest working conditions, and in this aspect it is precisely where we can provide all the experience accumulated over the years we have been designing and manufacturing machinery for this sector.

The NDF 6515/20-1400 Multiwire Cutter stands out for the following features:

- Independent tensioning system, which increases the useful life of the wires, increasing profitability and ensuring optimal surface finishes.
- Innovative design of the pulley, with a rotating extraction system that reduces maintenance time.

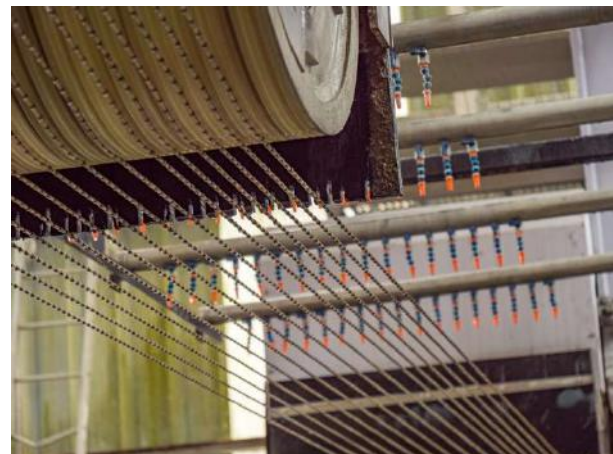

- Full range of cutting thicknesses, thanks to its special design of pulley packs and combination of grooves, without penalizing the life of the diamond wire.
- Excellent precision and flatness of cut, thanks to its particular guiding system with linear shoes and its rigid supporting structure.
- Easy and convenient access inside the machine, thus facilitating the work of replacing wires and their maintenance.
- Helical spindles with large diameter spheres in vertical movement for smooth or precise movements.
- Software-controlled synchronized servomotors in vertical movements that ensure smooth cut, low energy consumption, maximum precision and avoid gaps and problems of central motorization with transmission and advancement.
- Up to 20 wires with various possibilities for the combination of cutting thicknesses
- VERY FAST AND EASY FOR CHANGE WIRES AND PUT NEW WIRES..... 20 WIRES ONLY 30 MINUTES.



2 – STRONG POINTS:

The diamond wire cutter is a multiple wire cutter designed to produce slabs, panels and slabs of different thickness with large blocks of granite and natural stone. Traditionally in granite processing factories, the sawing of the blocks is made of the same dimensions with frames when the blocks are large, or with barks of large diamond disks in stone workshops when cutting semi-blocks.

Another aspect to note is that the multi-wire, for an equivalent capacity, the actual energy consumption, is lower than any of the methods used. This translates into significant energy savings both in implementation and in production costs.

As for consumables, say that there is only one in the thread cutter; diamond wire, small volume, easy storage and simple supply. The costs derived from storage, scheduling and inventory handling are also lower than for straps, shot and lime, which are necessary for the traditional loom.

In reference to the implementation costs, the simplicity and the consequent lower cost of the civil works stand out first, while in the frame the necessary work constitutes an indispensable part of it, in the multiwire cutter, this becomes a mere support. Moreover, in the case of renewal or replacement of the machine, the frame forces the new system to be exactly the same model as the previous one, while in the case of the multi-wire cutter there is a high degree of possibility to be able to adapt to the civil works existing. In any case important, that is, the space occupied by the multiwire is lower.

The simplicity of the multiwire is significantly greater, both in the installation, in the use and in the management, and in the maintenance, both mechanically and electrically. It is important to note that the multi-threaded NDF-6515/20-1400 cutter does not use the common solution for vertical movement consisting of a central motor with reducer, transmissions and angular advancement. This is replaced by two independent and electronically synchronized servomotors without coupling each other. This solution, in effect, eliminates the drawbacks of classical mechanical transmissions, the play and the possible breaks due to wear and fatigue, and also allows us greater flexibility in the movements to be performed. In this regard, it should be noted that the

system is capable of operating at speeds of one millimeter per minute, at most almost one meter per minute, all without loss of power or precision in movements.

As a practical effect, the NDF-6515/20-1400 cutter is the fastest machine on the market able to perform a vertical ascent movement in case of contingency avoiding the unwanted signs of the diamond wire in the stone.

The surface of the serrated end product with the diamond wire, in addition to the fact that it does not need to be practically washed, let alone the use of acids or harmful chemical substances and dangerous handling, offers the important advantage that its surface state can be assimilated to certain smoothness. In the event that the material is to be subsequently polished, a certain reduction in the costs associated with the abrasives used in the polishing process and the consequent reduction in production times should be noted.



The high speed from the multi-wire machine will also allow new users of this technology to program production with a lower advance and greater flexibility with respect to the frame, also allowing partially cutting a block and reserving the rest of it for another more appropriate time.

Production flexibility is also given by clearly lower staff requirements. The preparation of the saw in a wire cutter for a cut, consumes less than half the time and less than half of human resources compared to a traditional frame.

With this cutting unit we intend to integrate the completely automated operation of the primary sawing work of the stone blocks, with the minimum human intervention and therefore a significant reduction of the handling manoeuvres, regularization and optimization of the product of the work processes, increased capacity productive thanks to the reduction of cycle times and the efficient use of downtimes, the reduction of energy consumption and the production of waste during the cutting process, and finally the reduction of the associated risks for the personnel involved in the handling work and mechanization of materials during each working day.



3 – WHY BUY OUR MULTIWIRES:

The use of the diamond wire in primary sawing works has been used in the field for some years and said wire is applied to known machines, usually consisting of two pulleys on which a wire is installed forming a closed loop with which the cuts are made on stone blocks.

In recent years, machines that use multiple diamond wires have begun to be used, mounted on multi-channel drums or consisting of multiple pulleys, on which more wires are mounted to perform more cuts simultaneously on the stone blocks, thus obtaining significant productions.

The machines used up to now have various technical problems in achieving the correct tensioning and control of the loops, in addition to a more significant one which lies in the possibility of simply varying the position of the pairs of wires to obtain different thicknesses or vary them in the production of panels.

Taking these disadvantages into account, cutter No. 6510/20 stands out for its simplicity in the individual tensioning device of the tensioning wheels and at the same

time has simplified their separation to allow the variation of the working thicknesses on slabs and axes to be cut in a simple and easy way.

Nodosafér offers its customers in addition to all the intrinsic features of any threading machine, important improvements such as:

- Architecture based on a robust and compensated structure to avoid vibrations.
- Maximum protection against the penetration of water and dust into the most sensitive parts.
- Helical spindles with large diameter spheres in vertical movement for smooth and precise movements.
- Linear guides for re-circulating the rollers in the columns to guarantee the absolute verticality of the cut.
- Software-controlled synchronized servomotors in vertical movements that ensure smooth cut, low energy consumption, maximum precision and avoid gaps and problems of central motorization with transmission and advancement.
- Basic mechanism of the large diameter transmission drum which extends the life of the wire.
- Automatic tensioning device through independent pulleys of each of the wires, with position, arrow and tension control of each of the wires.
- Automatic and progressive speed reduction in case of an excessive arrow in the thread.
- Detection of wire breakage and controlled shutdown (rapid braking and increase in maximum speed).
- Controlled emergency stop to avoid marks on the cut block.
- Possibility to resume a cut automatically or semi-automatically.
- Wide range of devices and program functions for operator and machine safety.
- Motorized car with optional position control.
- Colour operator panel with manageability and multiple configuration possibilities.



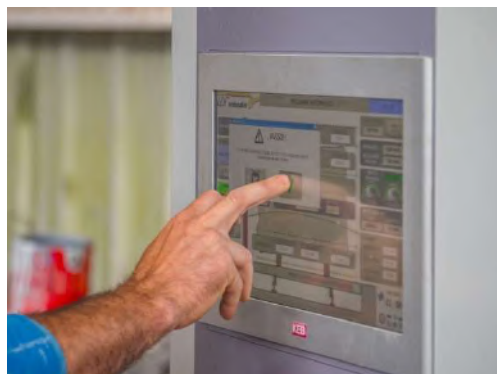

- Compact electrical panel with the latest technologies.
- High power main motor driven by inverter.
- Push-button panel for movements in manual mode.
- Automatic greasing.



4 – CONSTRUCTIVE DETAILS:

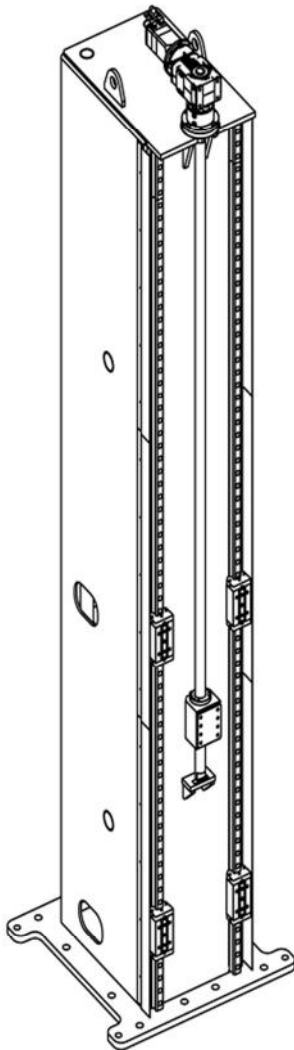
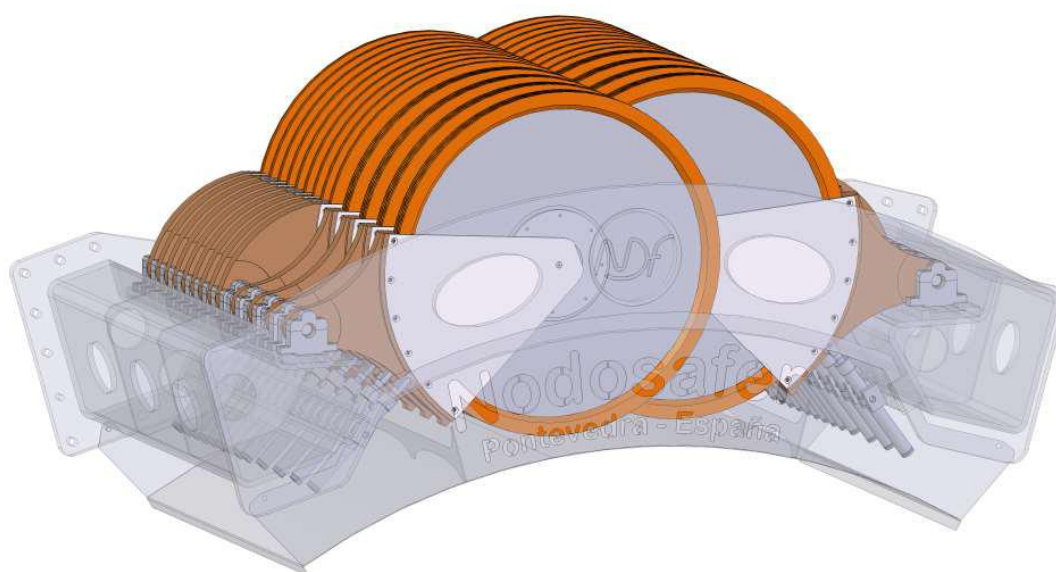

Fig. 1 – Column detail with linear guides, shoes, vertical movement spindles and servomotors



2 – Detail of the tension pulley unit, articulated arms and independent tension cylinders.

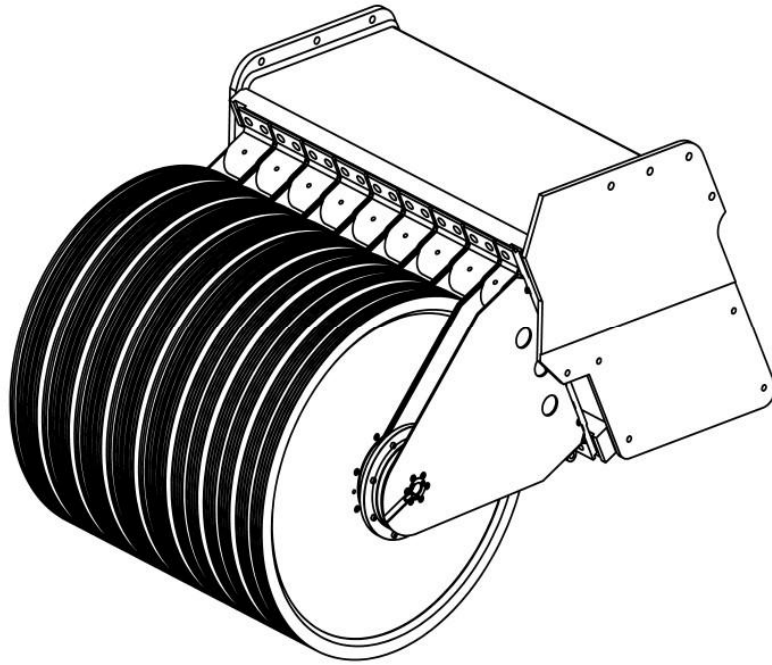

Fig.3 – Detail set of removable free pulleys with pivoting extraction system

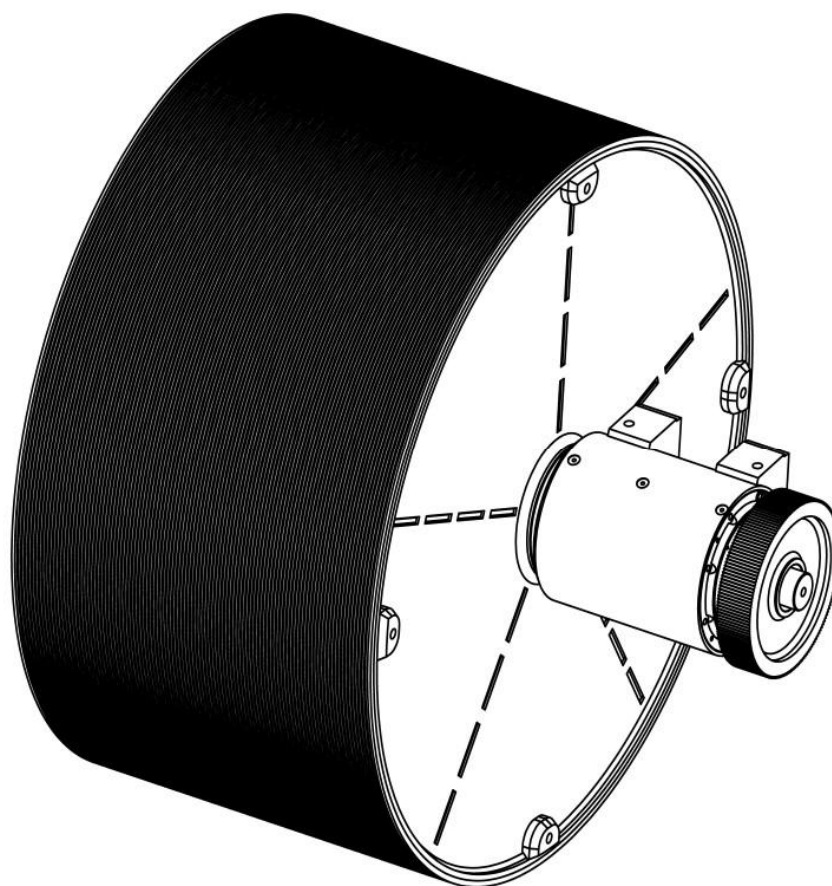

Fig. 4 - Detail of the engine drum unit, support and channels pulley

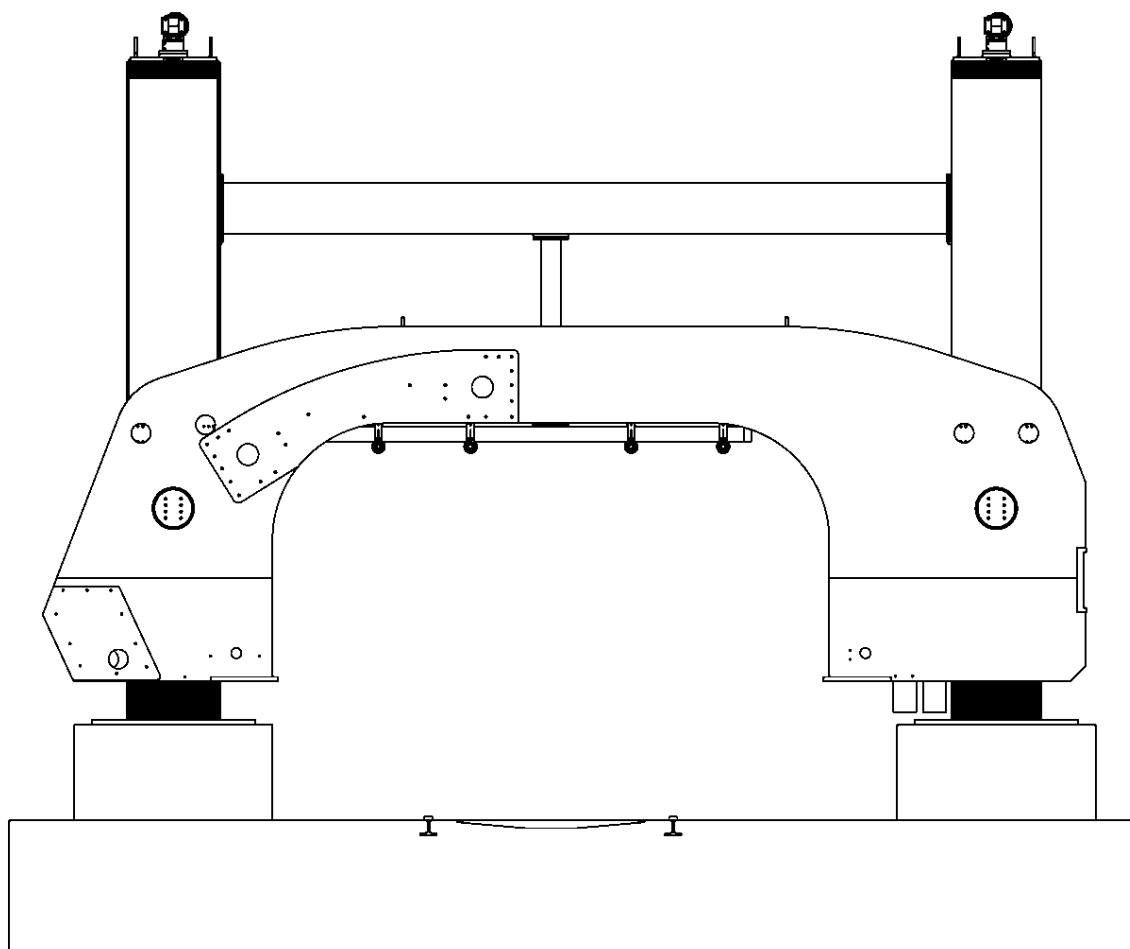

Fig. 5 - Detail of the main frame, columns and crossbar

5 - SAFETY

The NODOSAFER machines are protected gives a safety closure along its entire perimeter according to the CE safety standards.



6 – LOAD TROLLEY BLOCKS

The machine has TWO (2) motorized block carriage fitted as standard.



7. FEATURES:

MODEL	NDF.6515/20-1400
Number of WIRES	20 units
Machine height	6,75 mt
Machine length	10,60 mt
Block length	3500 mm.
Block height	2200 mm.
Thread length	22,40 mt
Diamond wire diameter	7,3 mm.
Vertical machine travel ECO	2300 mm.
Steering wheel diameter	1800 mm.
Minimum thickness cuttable	21 mm.
Tambour length (Cut length)	1400 mm
Diamond wire speed	0 – 35 mt/sc.
Main motor power	90 Kw

ALL NODOSAFAER MACHINES ARE PREDISPOSED FOR WORKS WITH OTHER DIAMETER WIRES ...

- ONLY NEEDS TO MAKE SOME LITTLE MODIFICATIONS iii